

# ELEVATE™

## Quick start guide for Universal Robots

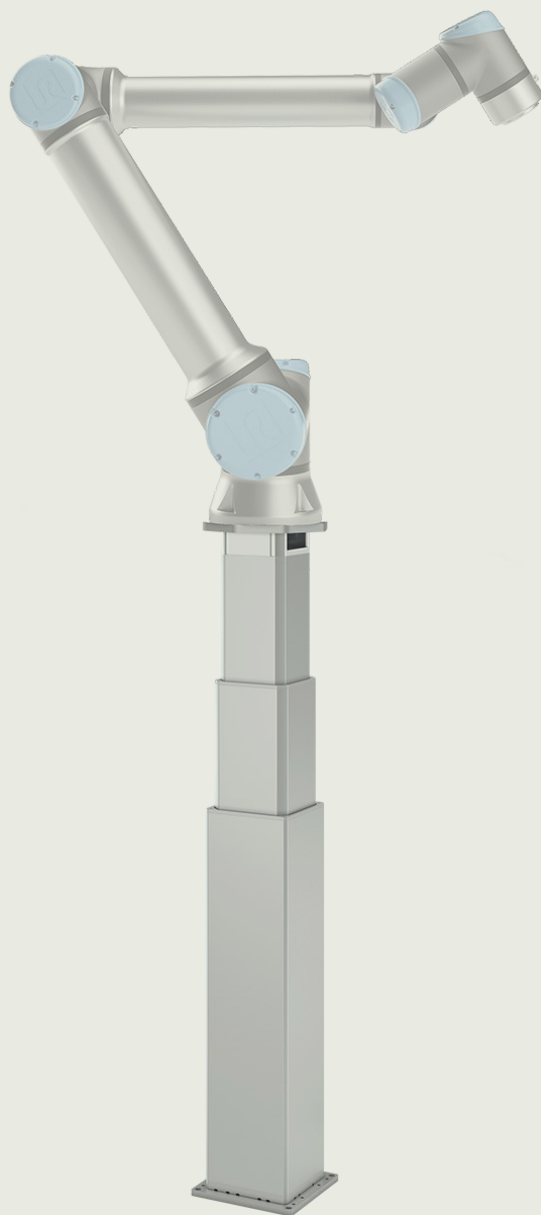

This quick start guide does not replace the user manuals of the included products.

## 1. Get your ELEVATE™ with an LC3 IC lifting column and accessory kit for UR

You will receive the following parts:



- Lifting column LC3 IC
- Mounting plate for UR cobots incl. screws to mount to the lifting column
- Base plate with screws to mount to the lifting column
- 5 m power cable
- 5 m signal cable
- Cable relief with screws for power and signal cable

## 2. Attach the UR mounting plate and the base to the column with the included screws

Make sure that the base of the column is proper mounted to the ground so the column will not tip over. It is important to use a solid ground since deflections on the ground influence the precision of the whole system.

## 3. How to attach and fit the cable relief

When the power cable and signal cable are connected to the lifting column, you can use the cable relief to secure both cables to the lifting column. Use a Torx Bit T15 screwdriver and make sure the screw is tightened with 1,6 Nm

## 4. Connect the column to the UR control box for e-Series

Be aware that *ELEVATE Easy*, *ELEVATE Pro* and *ELEVATE Modbus* are connected differently to the UR control box. Therefore you must make certain which model you own. The wiring diagram only displays one possible way to integrate ELEVATE into a safe torque off system – a risk assessment for the whole system is required.

The port number can be chosen during the setup of the URcap on the teach pendant.

Remember to place common ground between the power supply, safety relay and the UR controller. ELEVATE is by default delivered without safety relay/contactors and power supply.

### URCap wiring diagram for *ELEVATE Easy*

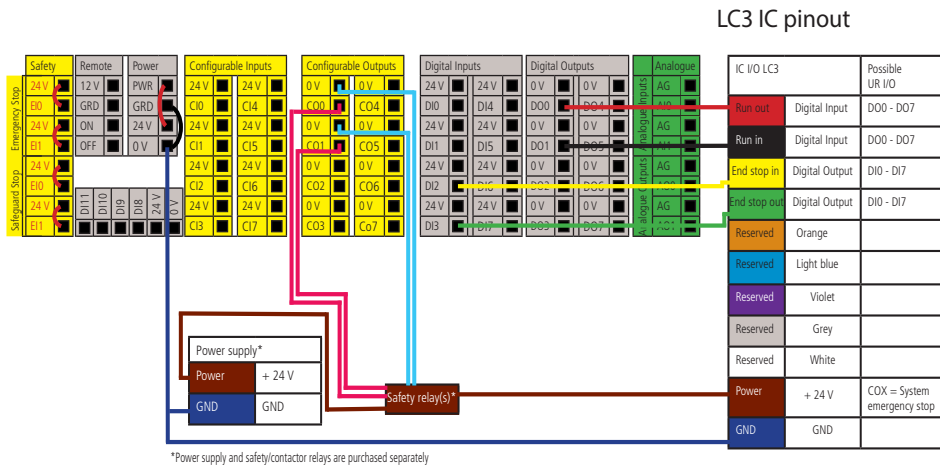

### URCap wiring diagram for *ELEVATE Pro*

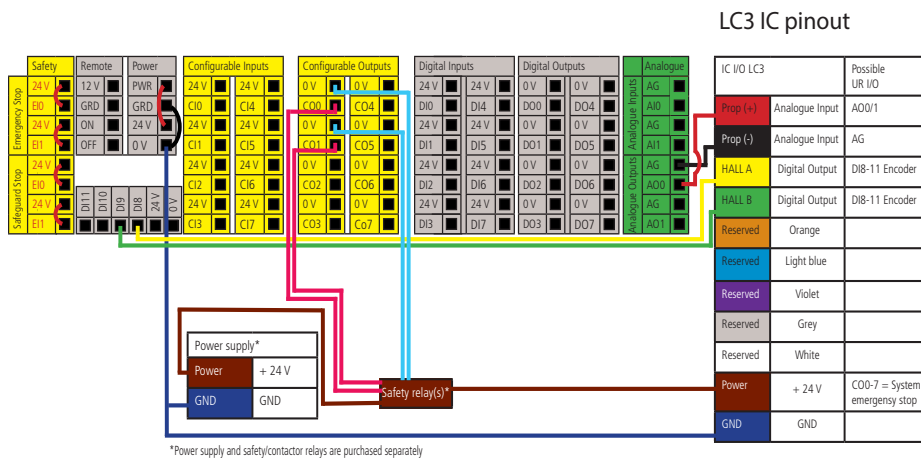

### URCap wiring diagram for *ELEVATE Modbus\**

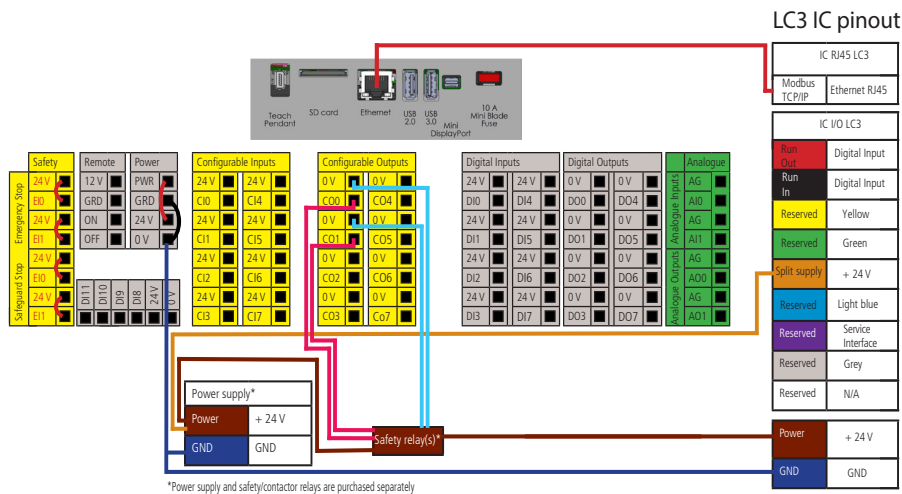

\*Ethernet cable is not included in the accessory kit.

## 5. Download the ELEVATE URCap from [linak.com](http://linak.com) and install it on your UR e-Series cobot

You can locate the ELEVATE URCap user manual inside the URCap. **Go to Installation / URCaps / ELEVATE / About**

## 6. Set up the ELEVATE URCap

Go to **Installation / URCaps / ELEVATE / General** and choose the correct interface

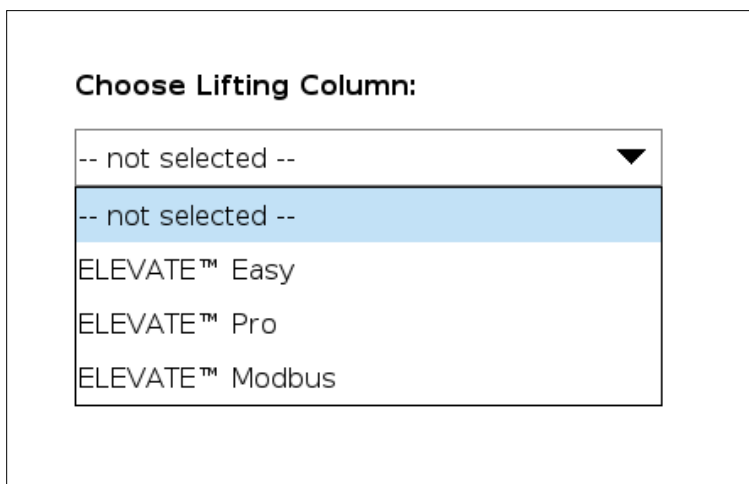

Thereafter, you can choose the correct I/O ports for *ELEVATE Easy/Pro* or enter the column's IP address for *ELEVATE Modbus*.

Make sure to add safety relay/contactors between the power supply and the column. Furthermore, you need to configure the system emergency stop output of the robot with the safety relay/contactors. The URCap will also ask you to do this.

**Note: ELEVATE Pro.** The signal type of the analogue output must be set to current 4-20 mA.

**Note: ELEVATE Modbus.** The control box need to have a static network address. Default network setting at the column are:

IP address: 192.168.1.10

Port number: 502

Subnet mask: 255.255.255.0

Gateway: 192.168.1.1

**SAFETY WARNING:** Don't forget to enable the **System Emergency Stop** output in Installation → Safety → I/O!

I have configured the System Emergency Stop signal and connected it to the lifting column.

[Test connection](#)

After approving the safety warning, you can test the connection. If everything is correctly set up, you will receive a confirmation.

The last step of the URCap set-up is to initialise the column. You can do this by going to **Installation / URCaps / Elevate / Overview**. During the initialisation, the column can move. You should be able to see the column's position after the initialisation.

## 7. Get started with ELEVATE™

When all prior steps are successfully completed, you begin to set up a robot program with a UR teach pendant.

The ELEVATE URCap has the following features:

- Program as many positions as you want
- Choose whether the robot and column move simultaneously or if the robot should wait for completion before moving
- Use the script function to control the column
- Use the UR+ tool to directly control the column or get status feedback from the column
- Change acceleration and deceleration depending on whether you target speed or smoothness



Watch the Universal Robots cobots training video here:



This quick start guide does not replace the user manuals of the included products.

---

#### **Terms of use**

LINAK® takes great care in providing accurate and up-to-date information on its products. However, the user is responsible for determining the suitability of LINAK products for a specific application.

Due to continual development, LINAK products are subject to frequent modifications and changes. LINAK reserves the rights to conduct modifications, updates, and changes without any prior notice. For the same reason, LINAK cannot guarantee the correctness and actual status of imprinted information on its products.

LINAK uses its best efforts to fulfil orders. However, for the reasons mentioned above, LINAK cannot guarantee availability of any particular product at any given time. LINAK reserves the right to discontinue the sale of any product displayed on its website or listed in its catalogues or in other written material created and produced by LINAK, LINAK subsidiaries, or LINAK affiliates.

All sales are subject to the 'Standard Terms of Sale and Delivery for LINAK A/S' available on LINAK websites.

LINAK and the LINAK logotype are registered trademarks of LINAK A/S. All rights reserved.